

EFR 7163-F

300 - 550 HP Turbo

EFR SERIES



Key Turbo Features

- Mixed Flow Gamma-Ti turbine wheel
- Dual ceramic ball bearing assembly with metal cage
- Water cooled Aluminum bearing housing
- Large internal wastegate
- T25 inlet connection

Not Included with Turbo Assemblies:

- Speed sensor
- Turbine outlet V-Band
- Turbine inlet gasket
- Oil drain gasket or drain port fitting

COMPRESSOR MAP

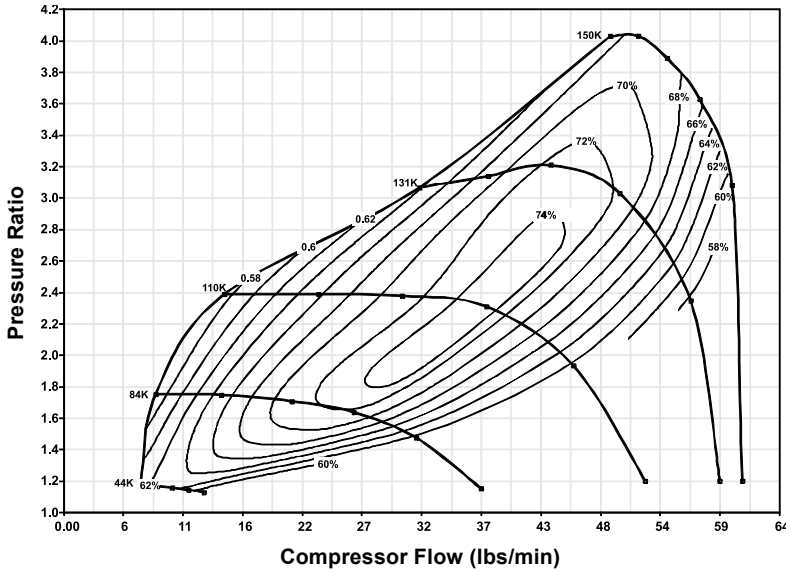

TURBINE HOUSING OPTIONS

Turbine Housing Part Number	A/R	Inlet Flange Shape	Housing Config.
11631008001	0.85	V-Band	V-Band, WG
11631008002	0.80	T4	Twin Scroll, WG
11631008003	0.85	V-Band	V-Band, Non WG

Turbo Part #	Turbo Frame Size	Super Core Part #	Comp. Wheel Outer Dia. (mm)	Comp. Wheel Inducer Dia.	Turbine Wheel Outer Dia.	Turbo A/R	Inlet Flange Config.
11639880005	B1	11637105000	71	57	63	0.85	T25

TURBO FRAME DIMENSIONS

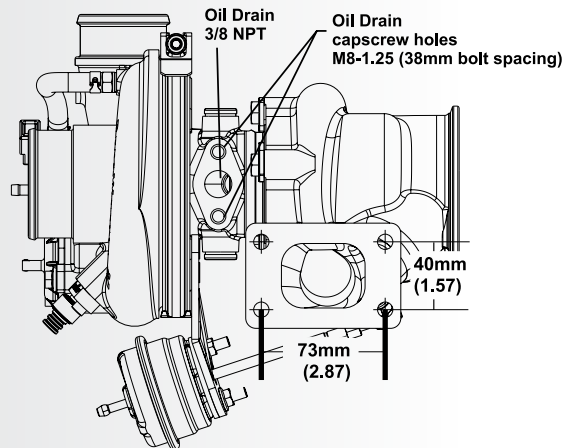
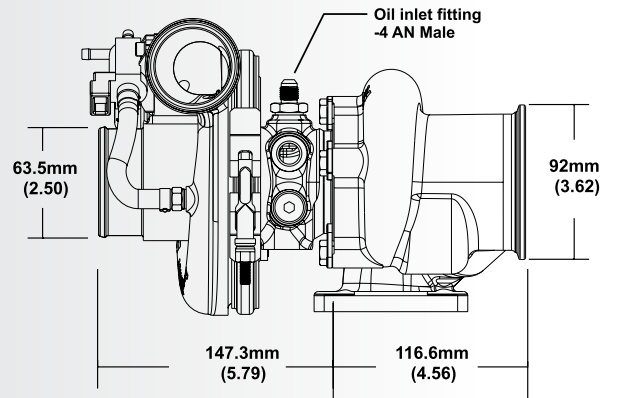
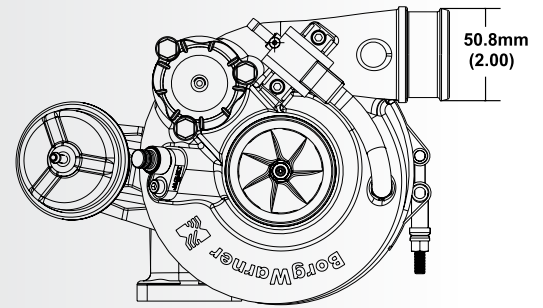

SUPER CORE CONFIGURATION

The following parts are not included as part of the super-core assembly: turbine housing, assembly clamp plate hardware, wastegate parts.