

HYPHERPRO

STEERING DAMPER MOUNTING KIT

for

MOTO MORINI 9½ 2006>
& CORSARO 1200 2005>

MK-MM12-S001 PART LIST

SD stroke 160	1	M8x60 button head	1
Tube Clamp TYPE 1	1	-	-
O-Ring	2	-	-
Fork Clamp Ø56	1	-	-
Frame Clamp Type 12	1	-	-
Spacer Type 1	2	-	-
M6x25	1	-	-
M8x35 button head	1	-	-

ALL IDEAS, DESIGNS ARRANGEMENTS AND PLANS INDICATED OR REPRESENTED BY THIS DRAWING ARE OWNED BY HYPERPRO AND WERE CREATED, EVOLVED AND DEVELOPED FOR USE ON AND IN CONNECTION WITH THE SPECIFIC PROJECT. NONE SUCH IDEAS, DESIGNS, ARRANGEMENTS OR PLANS SHALL BE USED BY OR DISCLOSED TO ANY PERSON, FIRM OR CORPORATION FOR ANY PURPOSE WHATSOEVER WITHOUT THE WRITTEN PERMISSION OF HYPERPRO.

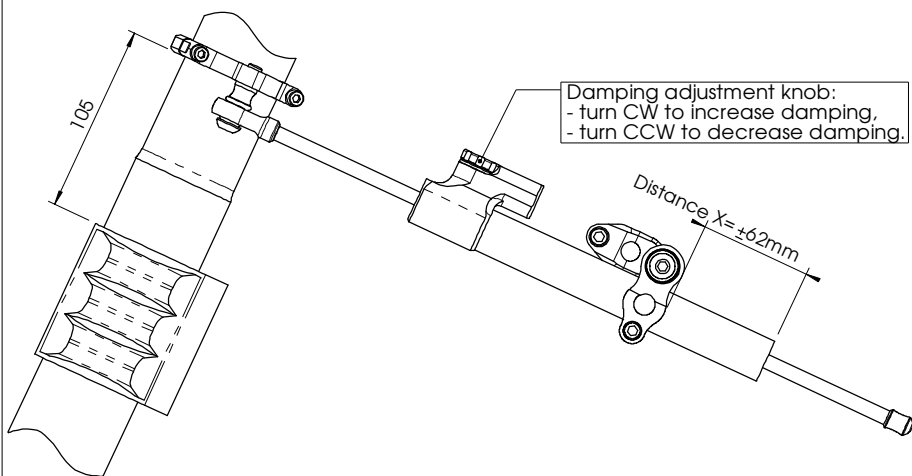
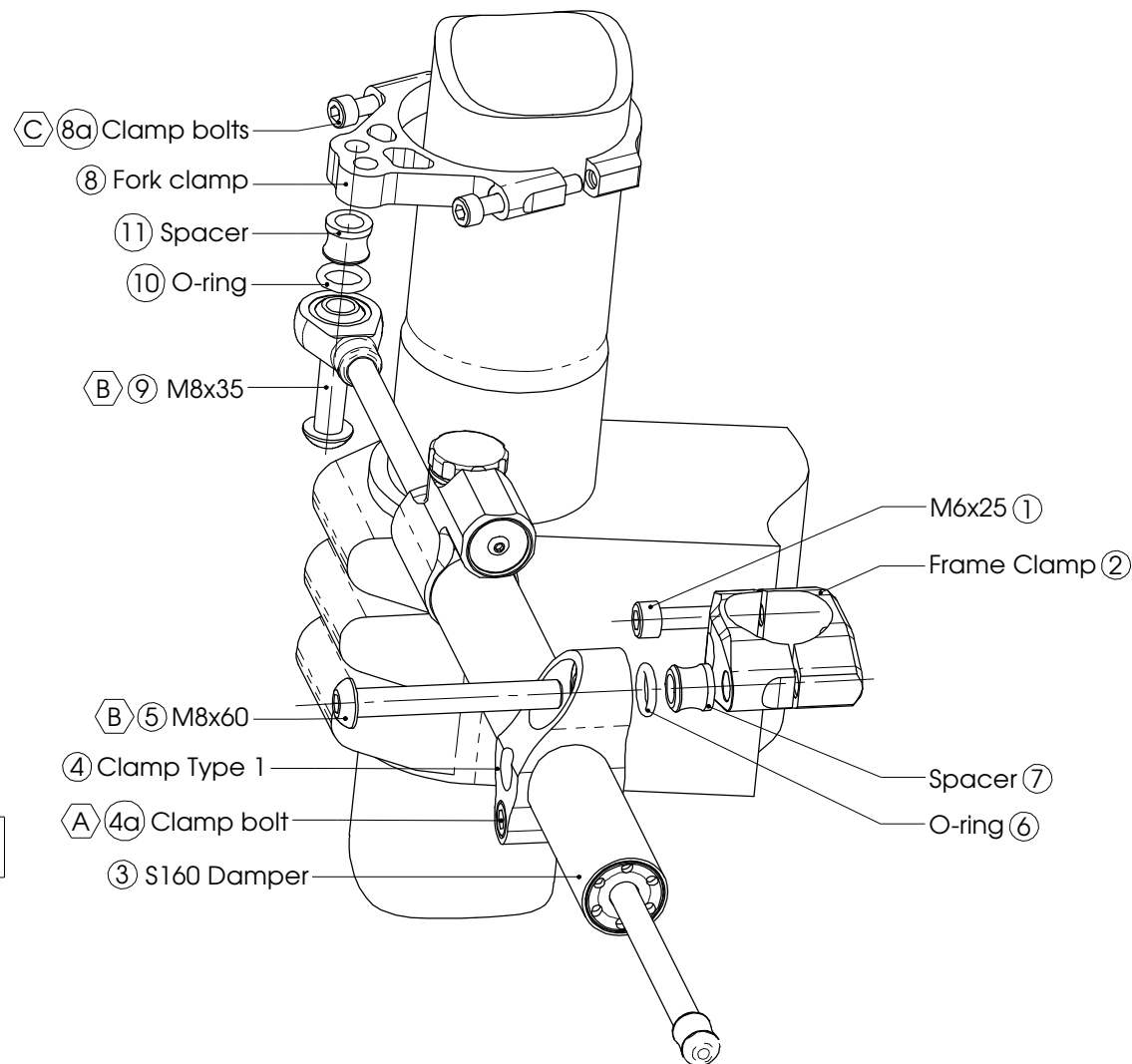

1
of 2

A 6Nm / 53Lbs.In / 4.4Lbs.Ft

C 8Nm / 70Lbs.In / 5.9Lbs.Ft

B 14Nm / 124Lbs.In / 10.3Lbs.Ft

See WWW.HYPERPRO.COM for the latest pictures, modifications, specs. and e-drawings of this steering damper kit.

HYPERPRO

STEERING DAMPER MOUNTING KIT

for

**MOTO MORINI 9½ 2006>
& CORSARO 1200 2005>**

MK-MM12-S001 INSTALLATION INSTRUCTIONS

In general:

HYPERPRO can not be held responsible in any way for any form of physical, material, financial or other damage arising from use, assembly or overhaul of HYPERPRO products. HYPERPRO reserves the right to make changes without prior notice.

This product is ONLY TO BE INSTALLED BY A PROFESSIONAL MECHANIC.

This product is only to be used for the motorcycle brand, model and year stated specifically on top of the pages of this manual.

DO NOT attempt to install this product on motorcycles from any different brand, model and/or year than stated on the pages of this manual.

DO NOT use this kit for cars, boats, jet-skies, snowmobiles, ATV's, aircraft, hovercrafts or any other vehical and/or purpose.

HYPERPRO steering dampers are FOR RACE USE ONLY, NOT FOR HIGHWAY USE!

Before installation:

- Please read the entire manual carefully before starting the installation!
- Check if you have all the tools required. Good tools are a must.
- Protect your bike at the most important places in and around the work area (e.g. tank, fairing, frame, etc.), with a blanket, towel or similar.

During installation:

- Check all operations and parts carefully before, during and after performing each step.
- Clean all surfaces that are required for fitting parts together or for applying self adhesives or loctite, thoroughly with contactcleaner or another degreaser, unless otherwise stated.
- Be careful not to damage or scratch any part of your bike.
- ALWAYS work relaxed and concentrated!! It is very easy to damage something or make a mistake.

After installation:

- Check and make sure that there is no contact between any part of the steering damper kit and any part of the motorcycle. The kit should not hit anything. Steering movement should not be limited by the steering damper. If the steering movement is limited, adjust the position of the tube in the clamp until steering movement is normal again. Do not forget to tighten the clamp bolt again!
- ALWAYS check the steering movement and feeling before each ride !
- FIRST RIDES: Start with the damper turned fully open (turn adjuster knob fully counter clockwise). Start adjusting in between rides with steps of MAX. 2 CLICKS (0.25 TURN) EACH TIME, until the damper is working satisfactory for your riding style.
- NEVER USE MAXIMUM SETTING, ALWAYS OPEN AT LEAST 2 CLICKS (0.25 TURN).
- WARNING ! DAMPER HAS AN ACTIVE / SPEEDSENSITIVE DAMPING SYSTEM;
 - Steering with NORMAL MOVEMENT should be FREE !!
 - Steering with FAST MOVEMENT should be CONTROLLED BY DAMPER !!
- HYPERPRO uses a special seal to reduce friction. The seal uses an oil film to work properly. It is normal that some oil can appear on the pistonrod.
- Damper works with oil: DAMPING CAN BE HARDER AT LOWER TEMPERATURES!

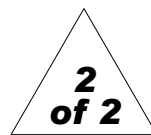

Step 1: installing the frame clamp

Install the frame clamp using:

- M6x25 (1)
- Frame clamp (2)

Install the frame clamp around the vertical frame tube on the left side of the bike, as shown on page 1. Tighten the bolt so the gap between the 2 parts is evenly spread on both sides.

Step 2: steering damper installation

Install the steering damper using:

- Steering damper, stroke 160 (3)
- Damper clamp Type 1 (4)
- Bolt M8x60 button head (5)
- 1x O-ring (6)
- 1x Spacer Type 1 (7)

Shove the damper (3), with the end knob first, through the clamp (4) until distance "X", stated on page 1 is reached, then tighten the M6 clamp bolt (4a) with a torque of approx. 6Nm/53Lbs.In/4.4Lbs.Ft. Use the M8 bolt (5) and O-ring (6) + spacer (7) to fit the damper clamp (4) to the frame-clamp (2). Tighten bolts (1) and (5) evenly, making sure that the gap between the 2 parts of the frame clamp stays equal on both sides. Finish by tightening the M8 bolt with a torque of approx. 14Nm/124Lbs.In/10.3Lbs.Ft.

Step 3: installing the fork clamp

Install the fork bracket using:

- Fork bracket Ø56 (8)
- Bolt M8x35 button head (9)
- 1x O-ring (10)
- 1x Spacer Type 1 (11)

Remove the 2 M5 clamp bolts (8a) from the bracket (8). Place the bracket parts around the left fork leg, 105mm above the lower triple clamp. Make sure that the clamp is fitted exactly as shown on page 1. Replace the clamp bolts, but do not fully tighten them yet.

Fit the damper (3) to the "short" hole (see page 1) of the fork clamp (8), using the bolt (9), O-ring (10) and washer (11). Do not fully tighten the bolt yet.

Turn the handle bars completely to the right and pull the damper rod fully out of the damper, then shove it back in a few millimeters.

Tighten the clamp bolts (8a) in this position with a torque of approx. 8Nm/70Lbs.In/5.9Lbs.Ft.

Finish by tightening the M8 bolt (9) with a torque of approx. 14-17Nm/124-150Lbs.In/10.3-12.5Lbs.Ft.

Check if the damper is level horizontally and aligned to the bike. Check if the damper does not touch anything (e.g. tank) when steering from left to right. Check if the bike can make it's full steering angle from left to right.

See WWW.HYPERPRO.COM for the latest pictures, modifications, specs. and e-drawings of this steering damper kit.