

HYPHERPRO

STEERING DAMPER MOUNTING KIT

for

Kawasaki Z1000 Model 2014->

MK-KA10-T009 PART LIST

SD stroke 75	1	M8x45 10.9	2
Tube Clamp (MP-DB0003)	1	Washer M6 ϕ 12	3
O-Ring	2	-	-
Fork Bracket (MP-FOMK93)	1	-	-
Tank Bracket (MP-TAMK83)	1	-	-
Spacer (MP-SP061512)	1	-	-
M6x35 Low head	3	-	-
M8x25 Button head	1	-	-

ALL IDEAS, DESIGNS ARRANGEMENTS AND PLANS INDICATED OR REPRESENTED BY THIS DRAWING ARE OWNED BY HYPERPRO AND WERE CREATED, EVOLVED AND DEVELOPED FOR USE ON AND IN CONNECTION WITH THE SPECIFIC PROJECT. NONE SUCH IDEAS, DESIGNS, ARRANGEMENTS OR PLANS SHALL BE USED BY OR DISCLOSED TO ANY PERSON, FIRM OR CORPORATION FOR ANY PURPOSE WHATSOEVER WITHOUT THE WRITTEN PERMISSION OF HYPERPRO.

Step 1: remove the tank cover
Step 2: remove the ignition lock cover
Optional : modify (cut) and re-install the modified ign. lock cover (see additional instructions)

Damping adjustment knob:
 - turn CW to increase damping
 - turn CCW to decrease damping

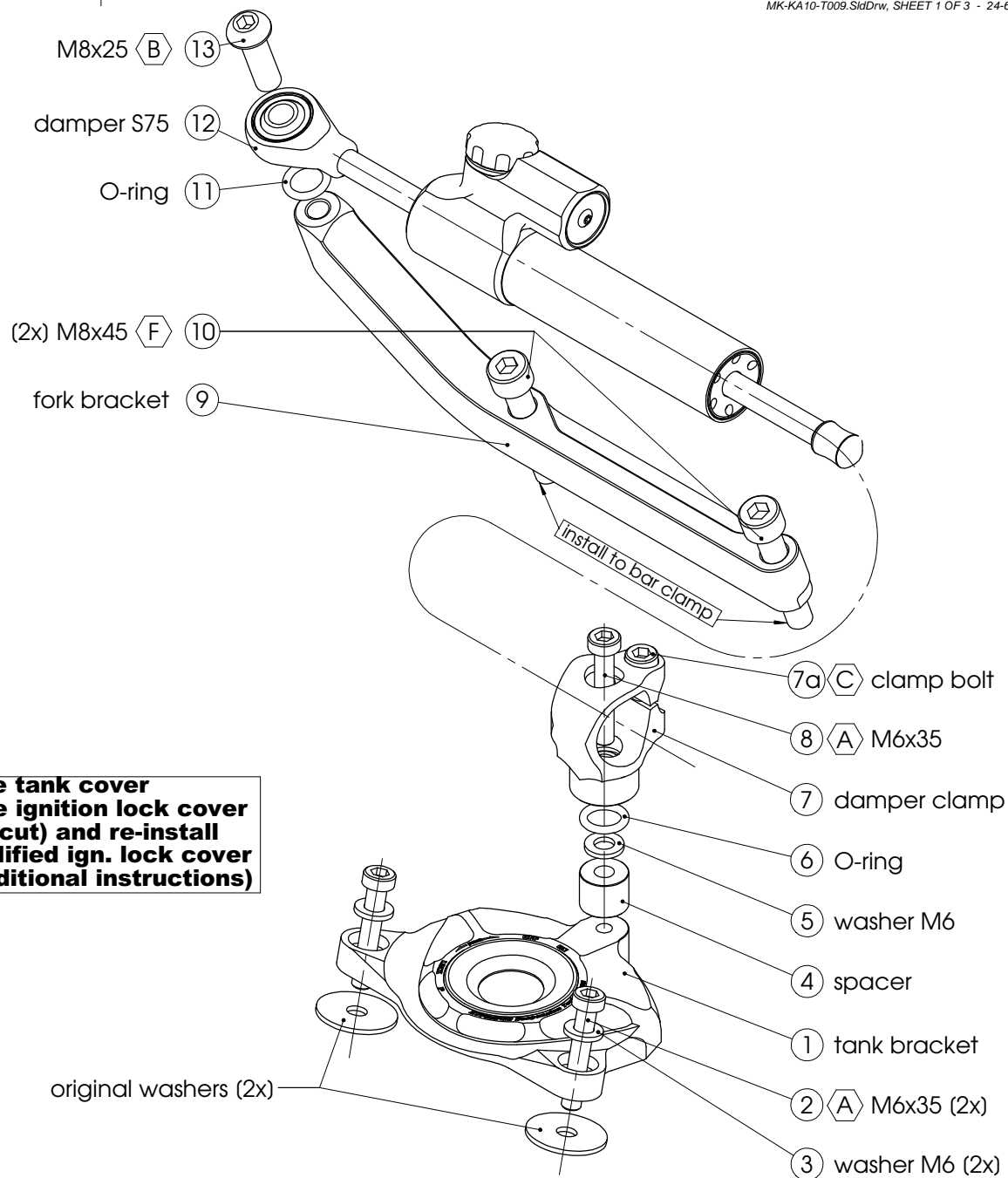
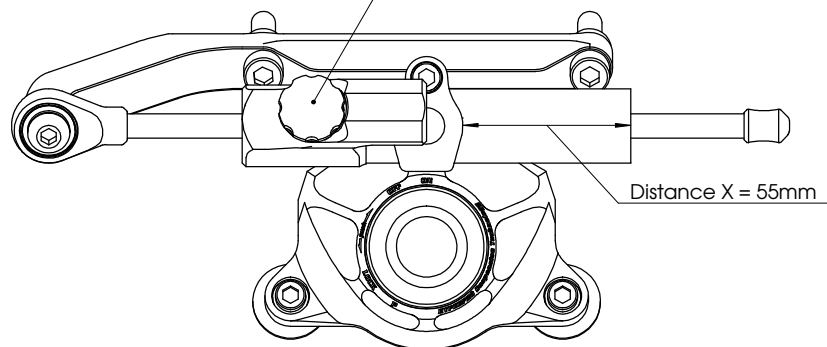

* TORQUES	
A: 5-9Nm / 44-80Lbs.In / 4.0-6.4Lbs.Ft	D: 8Nm / 70Lbs.In / 5.9Lbs.Ft
B: 14-17Nm / 124-150Lbs.In / 10.3-12.5Lbs.Ft	E: 55Nm / 486Lbs.In / 40Lbs.Ft
C: 6Nm / 53Lbs.In / 4.4Lbs.Ft	F: Factory torque (see owners manual)

HYPERPRO

STEERING DAMPER MOUNTING KIT

for

Kawasaki Z1000 Model 2014->

MK-KA10-T009 INSTALLATION INSTRUCTIONS

In general:

HYPERPRO can not be held responsible in any way for any form of physical, material, financial or other damage arising from use, assembly or overhaul of HYPERPRO products. HYPERPRO reserves the right to make changes without prior notice.

This product is ONLY TO BE INSTALLED BY A PROFESSIONAL MECHANIC.

This product is only to be used for the motorcycle brand, model and year stated specifically on top of the pages of this manual.

DO NOT attempt to install this product on motorcycles from any different brand, model and/or year than stated on the pages of this manual.

DO NOT use this kit for cars, boats, jet-skies, snowmobiles, ATV's, aircraft, hovercrafts or any other vehicle and/or purpose.

HYPERPRO steering dampers are FOR RACE USE ONLY, NOT FOR HIGHWAY USE!

Before installation:

- Please read the entire manual carefully before starting the installation!
- Check if you have all the tools required. Good tools are a must.
- Protect your bike at the most important places in and around the work area (e.g. tank, fairing, frame, etc.), with a blanket, towel or similar.

During installation:

- Check all operations and parts carefully before, during and after performing each step.
- Clean all surfaces that are required for fitting parts together or for applying self adhesives or loctite, thoroughly with contactcleaner or another degreaser, unless otherwise stated.
- Be careful not to damage or scratch any part of your bike.
- ALWAYS work relaxed and concentrated!! It is very easy to damage something or make a mistake.

After installation:

- Check and make sure that there is no contact between any part of the steering damper kit and any part of the motorcycle. The kit should not hit anything. Steering movement should not be limited by the steering damper. If the steering movement is limited, adjust the position of the tube in the clamp until steering movement is normal again. Do not forget to tighten the clamp bolt again!
- ALWAYS check the steering movement and feeling before each ride !
- FIRST RIDES: Start with the damper turned fully open (turn adjuster knob fully counter clockwise). Start adjusting in between rides with steps of MAX. 2 CLICKS (0.25 TURN) EACH TIME, until the damper is working satisfactory for your riding style.
- NEVER USE MAXIMUM SETTING, ALWAYS OPEN AT LEAST 2 CLICKS (0.25 TURN).
- WARNING ! DAMPER HAS AN ACTIVE / SPEEDSENSITIVE DAMPING SYSTEM;
 - Steering with NORMAL MOVEMENT should be FREE !!
 - Steering with FAST MOVEMENT should be CONTROLLED BY DAMPER !!
- HYPERPRO uses a special seal to reduce friction. The seal uses an oil film to work properly. It is normal that some oil can appear on the pistonrod.
- Damper works with oil: DAMPING CAN BE HARDER AT LOWER TEMPERATURES!

Step 1: remove the tank cover

Step 2: remove the ignition lock cover

*optional: modify and install the ignition lock cover

See the additional instruction sheet

Step 3: install the tank bracket

Install the tank bracket using:

- Tank bracket (1)
- 2x Bolt M6x35 (2)
- 2x original washers

Remove the 2 original M6 bolts and washers from the front tank mounting points.

Install the tank bracket (1) on top of the original washers, using 2 of the supplied M6x35 bolts (2), as shown on page 1. Tighten the bolts with a torque of approx. 5-9Nm/44-80Lbs.In/4.0-6.4Lbs.Ft

Step 4: install the damper clamp

Install the damper clamp using:

- Spacer (4)
- Washer M6 ϕ 12 (5)
- 1x O-Ring (6)
- Damper Clamp (7)
- Bolt M6x35 Low head (8)

Put the assembly together as shown on page 1: install the damper clamp (7) to the tank bracket (1) using the spacer (4), washer (5), the O-ring (6) and the M6 low head bolt (8).

Tighten the bolt to a torque of approx. 5-9Nm/44-80Lbs.In/4.0-6.4Lbs.Ft.

Step 5: install the fork bracket

Install the fork bracket using:

- Fork bracket (9)
- 2x Bolt M8x45 (10)

Remove the original handlebar clamp bolts. Fit the fork bracket (9) to the bar clamp using the supplied M8x45 bolts (10). Tighten the bolts to factory torque (or \pm 25Nm/220Lbs.In/18Lbs.Ft.).

Step 6: install the steering damper

Install the steering damper using:

- Steering damper, stroke 75 (12)
- 1x O-ring (11)
- Bolt M8x25 button head (13)

Shove the steering damper (12), with the adjuster knob-side first, through the clamp until the distance "X" stated on page 1 is reached and rotate the damper body to the correct angle, then tighten the M6 clamp bolt (7a) to a torque of approx. 6Nm/53Lbs.In/4.4Lbs.Ft.

Use the O-ring (11) and M8 bolt (13) to mount the damper head to the tank bracket and tighten the bolt to a torque of approx. 14-17Nm/124-150Lbs.In/10.3-12.5Lbs.Ft.

Check if the damper is level horizontally and aligned to the bike. Check if the damper does not touch anything (e.g. tank) when steering from left to right. Check if the bike can make it's full steering angle from left to right. Adjust the position of the damper body if necessary to improve fitment.

Step 6: install the tank cover

***OPTIONAL : Modify the ignition key cover**

Skip this page if you do not want to cut the original part. The mounting kit can also be fitted without this part.

