

FORK DAMPER KIT

HONDA/MONKEY 125 '18

HONDA/MSX GROM 125 '20

HONDA/ST125 DAX '22

Y-FDM36-KIT-01-001 (65-90 kg.)

Y-FDM36-KIT-01-002 (90-110 kg.)

Y-FDM36-KIT-01-003 (65-90 kg.)



INSTRUCTION MANUAL

NOTE: This Symbol Points out important Safety Instructions which if not followed could endanger your Personal Safety. Read and follow all Instructions in this Installation manual and any others provided with this equipment.

"Please note that there can be small differences between your product and the Images in these Instructions"

Included in this Fork Damper Kit is the following :

1. YSS Fork Cap M36	2 Pcs.
2. YSS Cap Nut Lock	2 Pcs.
3. Damping Rod (Compression)	1 Pcs.
4. Damping Rod (Rebound)	1 Pcs.
5. YSS Fork Spring	2 Pcs.
6. YSS Fork Fluid NO. 10 (250 ml)	2 Pcs.

YSS SPECIAL TOOLS.

A. Fork Tube Clamping Tool 3lx49x50 mm.	OV99-82IA90
B. Oil Volume Measuring Tube 100 ml.	OV99-056-00

WARNING!
Before installing your YSS Product, Read the Instructions.
Incorrect Installation will affect the Stability of your Motorcycle.

WARNING!
YSS Fork Damper Kit must be installed by an Authorized YSS Service Center

REMOVE ORIGINAL FRONT FORK

1. Place the Motorcycle on the Centerstand so that the front wheel barely touches the ground.
2. Remove Front Fender, Brake Calipers, Speed Sensor (if present) and Front Wheel.
3. Note Front Fork Leg Position and Measure
4. Loosen Upper Triple Clamp Bolts
5. Loosen Lower Triple Clamp Bolts
6. Remove Front Fork Legs from Triple Clamps

DISASSEMBLE ORIGINAL FRONT FORK

1. Loosen Top Cap from Outer Tube
2. Slide Outer Tube down until it stops.
3. Remove Top Cap from Original Damping Rod to instructions in the vehicle service manual.
4. Drain Front Fork leg of Suspension fluid.
5. Clamp the Steel tube in a vice by using the tool OV99-82IA90
6. Use a heat gun to soften the thread-locking adhesive between the Steel tube and the Axle clamp
7. Loosen the Axle clamp from the steel tube. (Do not loose the o-ring)
8. Remove the bottom cap
9. Remove Original Part & Original Fork Spring As per Picture (b)
10. Remove the Original Damping rod.
11. Remove the Original top out spring and the Original Piston ring.

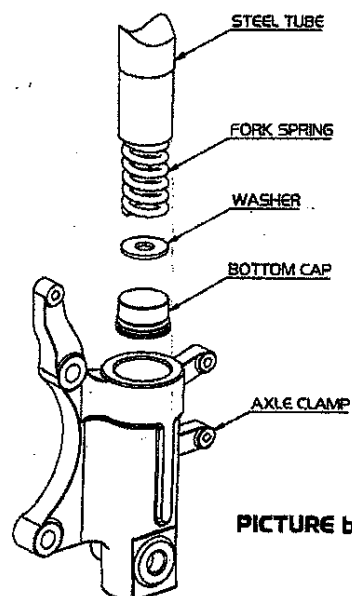
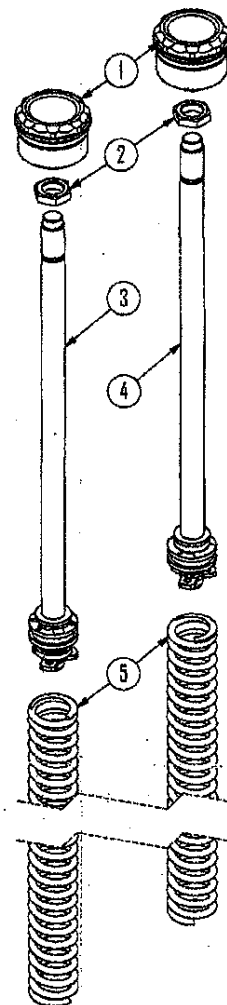
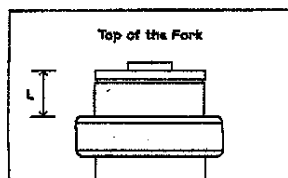

PICTURE b.

INSTALL YSS FORK DAMPER KIT

1. Install the previously removed Piston Ring to the YSS Damping Rod as per Picture (c)
2. Install the Top out spring to YSS Damping Rod and insert into the steel tube.
3. Clamp the steel tube in a vice by using the tool OV99-82IA90
4. Insert the YSS Spring and the Original Washer into the steel tube.
5. Apply grease on the o-ring on the bottom cap and install it. Tighten with a torque value of 40 Nm.
6. Compress the fork and install the YSS Cap nut lock on the YSS Damping Rod.
7. Install the previously removed Bump rubber and Steel washer to the YSS Fork cap M36 as per Picture (c). Tighten with torque value of 25 Nm, and use Loctite 243.
8. Fill the fork leg

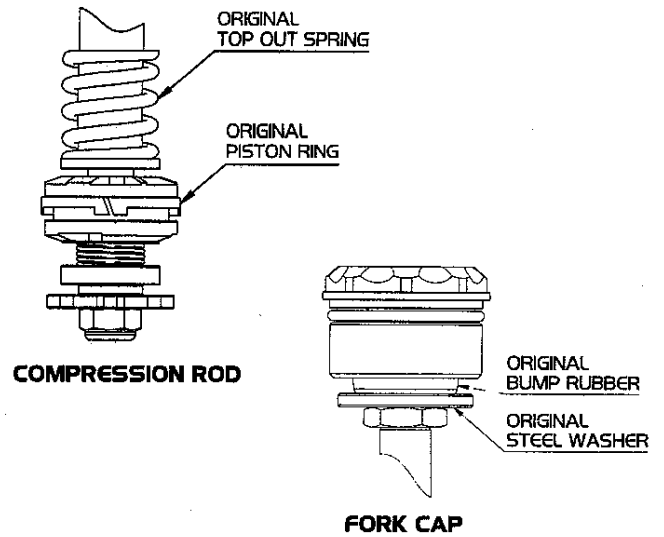

Oil No.	Model		
	Monkey	Grom	ST125 DAX
10 W.	200 ml.	190 ml.	200 ml.

9. Apply grease on the o-ring on the YSS Fork Cap. Extend the fork leg and tighten the cap to the outer tube.
10. Apply Loctite to the steel tube. Clamp the Axle clamp in a vice and tighten it with the steel tube with a torque value of 70 Nm.
11. Install Front Fork Legs into Triple Clamps, set Fork Position, torque bolts to Factory Service Manual Specifications
12. Remaining Installation, Refer to Factory Service Manual.

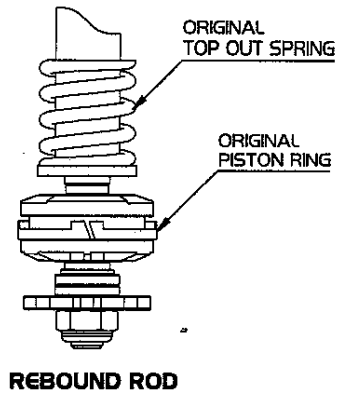

PICTURE c

YSS VIDEO SUPPORT
 INSTALLATION INSTRUCTION MANUAL
www.ysssuspension.com



Y.S.S. (THAILAND) CO.,LTD.
 88, 788 M.9 SOI PHIKULTHONG
 THEPHARAK RD, BANGPLA, BANGPHU,
 SAMUTPRAKARN 10540 THAILAND
 TEL : +66 2763 8600
 e-mail : cs@yss.co.th
www.ysssuspension.com
www.facebook.com/YSS-THAILAND

WORLD CLASS SUSPENSION
 HONDA
 MONKEY 125 '18
 MSX GROM 125 '20
 ST125 DAX '22



INSTALLATION INSTRUCTIONS
**FORK
 DAMPER KIT**



4J8I-300-02