

MEMBER  
**ABYC**  
Setting Standards for Safer Boating®

# INSTALLATION INSTRUCTIONS AND OWNERS MANUAL

Part # IS-CH2200/2300, Rev 1, 08/2013

[www.seastarsolutions.com](http://www.seastarsolutions.com)



SIDE MOUNT  
BOAT CONTROL  
CH2200P (SKI BOAT) / CH2300P (JET BOAT)

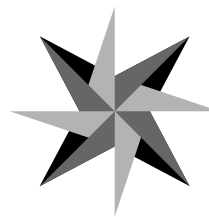

SEASTAR  
SOLUTIONS®

*Before you do it your way,  
please try it our way.*

*ch2200  
ch2300  
mt3  
osprey  
pro-trim  
single s  
twin s  
sl-3*

MANUFACTURED BY  
MARINE ACQUISITION INCORPORATED  
DBA SEASTAR SOLUTIONS  
U.S.A.

# SIDE MOUNT SINGLE LEVER CONTROL

CH2200P

CH2300P

## NOTICE

*Installer: these instructions contain important safety information and must be forwarded to the boat owner.*

*These instructions describe how to install CH2200P and CH2300P series side mount controls. (The CH2300P Series controls have limited-travel throttle warm-up movement to prevent boat travel while in neutral for jet boat applications).*

*In addition to this control, the following components are required for a complete control system:*

- Two 3300/33C Series Control Cables.
- One (1) Neutral Safety Switch Kit (P/N CA27090P for CH2200P Series Controls). Required if "Start in Gear" protection is not provided by the Engine Manufacturer.

## NOTICE

*The CH2200P control does not provide "Start in Gear" protection. If required, it can be added and is sold as a service item, or may be provided by the engine manufacturer. A neutral safety switch is standard on CH2300P controls.*

*Cable installation and connections must be made in accordance with the motor manufacturer's instructions.*

*To insure best performance, free operation of all linkages and the remote control is essential. Follow the manufacturer's recommended procedures for adjustment and lubrication.*

*All specifications and features are subject to change without notice.*

## ⚠ WARNING

**Before starting installation read these instructions and engine makers instructions thoroughly. Failure to follow either of these instructions or incorrect assembly can result in loss of control and cause property damage, injury, or death.**

## ⚠ WARNING

**DO NOT substitute parts from other manufacturers, they may cause a safety hazard for which SeaStar Solutions cannot accept responsibility.**

## NOTICE

*SeaStar Solutions highly recommends the installation and usage of an engine shut off switch as a important emergency safety feature for boats. This switch should be connected by a cord to the boat driver. Should the driver be thrown from the helm position, the engine will automatically shut off.*

*This shut off switch is not a standard part of this control. It can, however, be obtained from most marine dealers and distributors.*

## Preparation for Mounting Control

**STEP 1.** Select a location for the control ensuring that the handle does not interfere with dashboard, steering wheel, seat, switches, or other equipment at any point in its travel.

### NOTICE

*Thickness of mounting surface must not be greater than 1/2".*

Also insure that the shift cable will have a least 36 inches of unrestricted space for movement (see INSTALLATION OF SHIFT CABLE). Refer to Figure 1 for dimensions and clearances.

### NOTICE

*Control can be mounted horizontally or vertically to facilitate cable clearance.*

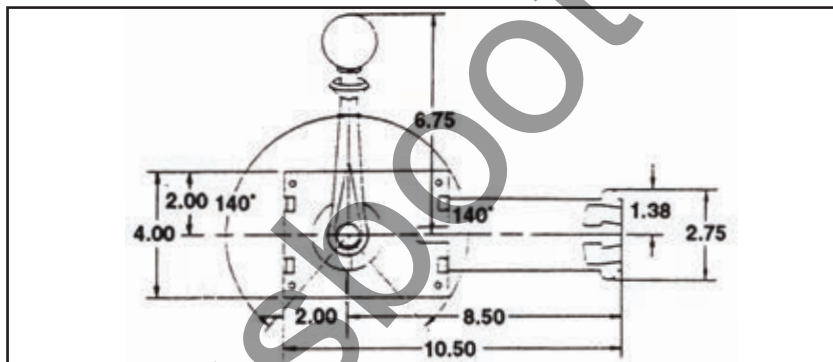

Figure 1.

**STEP 2.** Cut mounting holes in selected location, using template provided.

**STEP 3.** If not already routed, route the cables to the cutout, allowing the cables to protrude from the cutout enough to allow connection to the control mechanism.

## Installation of Cables

**A. BEND RADIUS.** When routing the control cables, select a path with the minimum number of bends, making the bends as large as possible. Sharp or frequent bends will result in difficult throttle or shift control, loss of motion, and premature cable wear. **DO NOT MAKE BENDS OF LESS THAN THE RECOMMENDED MINIMUM BEND RADIUS AS NOTED BELOW.**

Cable Type	Minimum Bend Radius
Standard 3300/33C	8"
Xtreme 3300/33C Cable	4"

For best performance, SeaStar Solutions recommends using Xtreme cables with this control.

**B. SUPPORTING THE CABLE.** Do not tie or clamp the cable within 36 inches of the control. When supporting the cable beyond 36 inches of the control, cables should be loosely clamped or tied for support at regular intervals.

**CAUTION**

Cables must not be bundled together with electrical wiring.  
Cables must not rest on sharp edges which can cause chafing.

**C. CABLE ROUTING.** Cables shall not be installed in areas of excess heat such as on, or close to, exhaust manifolds where temperatures may exceed 212 °F (100 °C).

## Connection of Cables

**NOTICE**

Always connect the cable to the mechanism before connecting it to the engine and gear. Engine connection should not be made until the control has been completely installed.

### A. CONNECTION OF THE THROTTLE CABLE.

**STEP 1.** Remove the nut (Figure 2 item A) and both rubber seals (Figure 2 item B). Push the throttle cable through the retainer (Figure 2 item C). Apply a light, even coating of a good waterproof marine grease to the terminal. Refit both rubber seals and nut.

**STEP 2.** Secure the cable with the hitch pin (Figure 2 item D). Note that the hitch pin must be fitted with the flat side upwards.

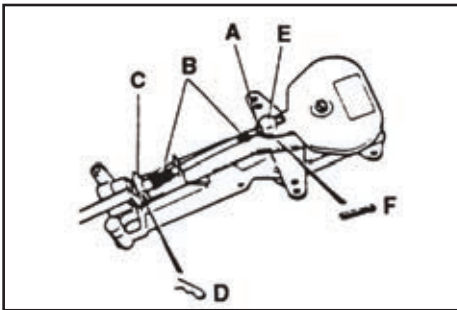

Figure 2.

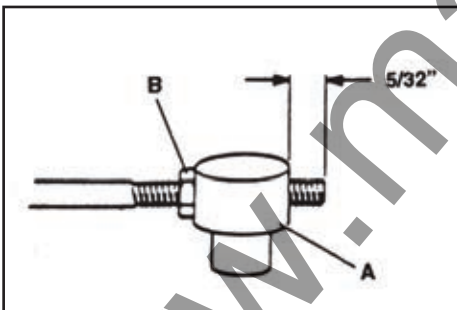

Figure 3.

**STEP 3.** Thread the pivot (Figure 3, item A) onto the cable terminal until the threaded portion of the terminal protrudes 5/32" (5 threads). Secure the pivot by tightening the nut (Figure 3, item B). Connect the pivot to the throttle lever (Figure 2 item E) and secure it with a cotter pin (Figure 2 item F).

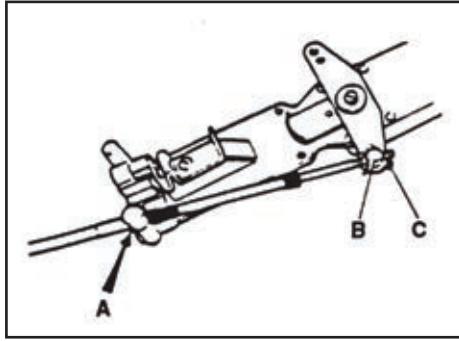

Figure 4.

## B. CONNECTION OF THE SHIFT CABLE.

**STEP 1.** Push the shift cable through the appropriate retainer, making sure the cable seats securely into the retainer (Figure 4, item A).

**STEP 2.** Thread the pivot (Figure 3, item A) onto the cable terminal until the threaded portion of the terminal protrudes 5/32" (5 threads). Secure the pivot by tightening the nut (Figure 3, item B).

**STEP 3.** Connect the pivot to the shifting lever (Figure 4 item B) and secure with a cotter pin (Figure 4 item C).

## Throttle Brake Adjustment

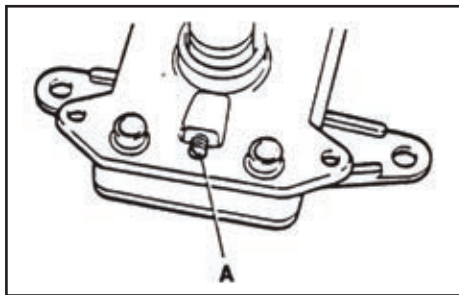

Figure 5.

The control mechanism is equipped with an adjustable friction device (brake) for the throttle to prevent throttle creep. If needed, the friction device can be adjusted by turning the adjustment screw (Figure 5, item A) clockwise to increase braking and counterclockwise to decrease or remove braking. Any adjustments should be made with the control set at 1/2 throttle and the gear engaged. Gear Shifting is not influenced by the brake.

## Neutral Safety Switch Installation

A neutral safety switch prevents the boat's engine from starting in gear and is required if "Start in Gear" protection is not provided by the engine manufacturer. Follow instructions packed with the neutral safety switch kit for installation and wiring.

### A. CH2300 CONTROL.

**STEP 1.** Route the wires so they will not in any way come in contact with the cable or moving parts of the control. If necessary, the switch can be relocated to the right side.

**STEP 2.** Connect one wire of the switch to the “Start” terminal on the ignition switch and the other to the positive terminal of the starter solenoid (see Figure A and warning).

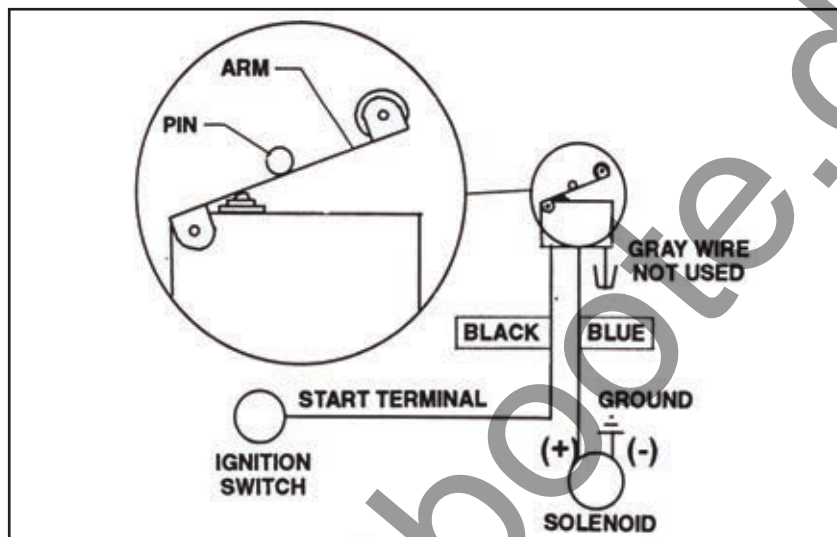

Figure A.

**⚠ WARNING**

Connection to the ground terminal of the solenoid will short circuit and destroy this switch.

**⚠ WARNING**

Check for correct operation by trying to start the engine at all gear lever positions. If the engine starts in either forward or reverse positions, check connection at ignition switch.

**B. ALL OTHER CONTROLS.**

Follow instructions provided with the neutral safety switch kit.

## Installation of Control

**A. INSTALLING THE MECHANISM.**

**STEP 1.** Make sure the control is in gear and at the half throttle position. This will allow the control to fit in the cutout shown in the template. If not already in half throttle position, use the handle to move in gear and at half throttle position by temporarily placing the handle on the splined shaft of the control. Push the mechanism until it seats flush against the mounting surface of the boat.

**STEP 2.** Secure the control mechanism to the boat with the four screws provided.

**B. INSTALLING THE COVER (IF SUPPLIED).**

**STEP 1.** Place the cover over the shaft and spline and snap into place on the control mechanism.



### C. INSTALLING THE HANDLE.

Once the mechanism has been securely mounted, the handle assembly may be attached to the control. The handle assembly contains two (2) sets of internal splines; one (1) on the chrome locking ring, and one (1) on the black handle. There are two (2) sets of mating external splines on the mechanism; one (1) on the cast housing and one (1) on the steel shaft. Each set of splines contains forty-eight (48) teeth and both sets of the 1 3/8" splines and 3/4" splines are consistently oriented to the other (See Figure 6)

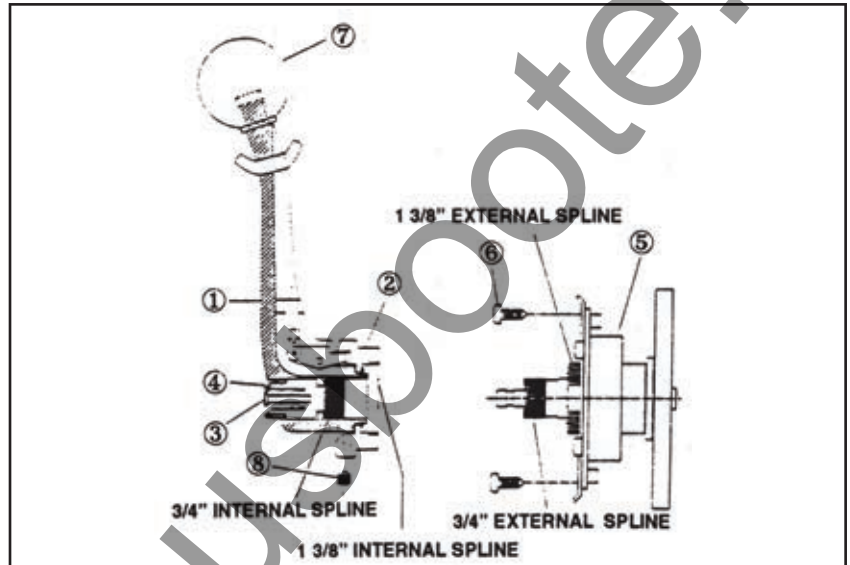

Figure 6.

**STEP 1.** Make sure the pinned rocker in the handle is situated in the slot in the locking ring; this is referred to as the locked position.

**STEP 2.** Firmly install the handle assembly onto the control so that both sets of splines are fully engaged and the steel shaft “bottoms-out” against the internal shoulder of the handle. Since the splines on the shaft and handle will engage before the splines on the locking plate and diecast housing, make sure the locking ring rests securely on the 1 3/8" splines and cannot rotate.

**STEP 3.** While applying pressure firmly against the assembly and leaving the handle in the locked position, install the set screw into the bottom of the handle and tighten.

**STEP 4.** Once the handle has been attached with the set screw, insert the black button onto the push pin in the shaft and press firmly. Insert the #6-32 x 7/8" long machine screw through the center of the button and tighten until the screw is flush with the button. Overtightening can result in damaging the button and/or screw.

#### NOTICE

*Once the assembly has been fully attached and the engine turned off, lift the “umbrella” of the handle and cycle the handle through full forward and full reverse to ensure that both sets of splines are fully engaged. If the locking plate is capable of rotating with the handle, remove the handle assembly and repeat the handle installation procedure. Also, cycle the control using the push button/neutral warm-up to ensure that the black button has been properly installed.*

## NOTICE

Since the sets of splines are oriented and have the same number of teeth, the control allows for the handle assembly to be indexed every 7.5°. The centerline of the handle is aligned with the centerline of the control, so if the control is mounted horizontally, the handle can be attached perpendicularly to the control.

## Connection of Cables to Engine

Read engine maker's manual and connect control cables to engine following those instructions, using attachment kits recommended by the engine manufacturer.

## NOTICE

Having the control lever and the transmission lever both in forward gear will help with your final shift cable adjustments.

## Parts List

ITEM	DESCRIPTION	QUANTITY
1	Handle	1
2	Locking Ring	1
3	Neutral Detent Warm-up Button	1
4	Button Mounting Screw	1
5	Control Mechanism	1
6	Control Mounting Screw	4
7	Knob	1
8	Handle Mounting Set Screw	1
9*	Pivot, Small (3/16") Dia. Thread	2
10	Hitch Pin (Figure 2 Item D)	1
11	Cotter Pin (Figure 2, Item F)	2

\* See Figure 3, item A.



## Operation of Control

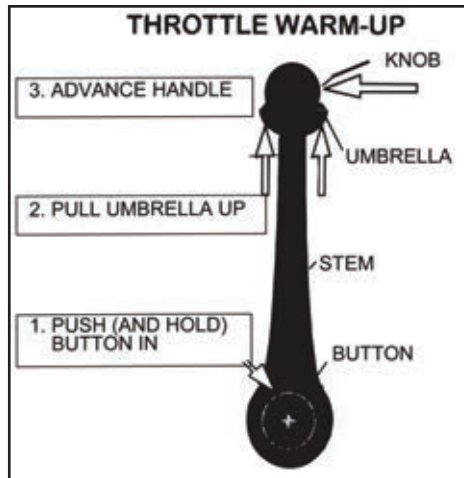

Figure 7.

### THROTTLE WARM-UP IN NEUTRAL POSITION.

To start the boat's engine and to activate the throttle for engine warm-up, the handle must be in the neutral position. Neutral can be found by rotating the handle (by grasping the knob or stem) until the handle locks in position and can not be rotated in either direction. Usually the handle is vertical as shown in Figure 7 when in the neutral position.

Push in the button with your left hand while grasping the umbrella and knob with your right hand and pull the umbrella up toward the knob (see Figure 7). While still holding the button and umbrella, advance the handle forward to put the control in warm-up throttle mode. Once in this mode, the button and umbrella can be released and throttle can be adjusted by simply moving the control handle away from the neutral position to increase throttle and towards the neutral position to decrease throttle. Returning the handle to the neutral position will disengage throttle warm-up.

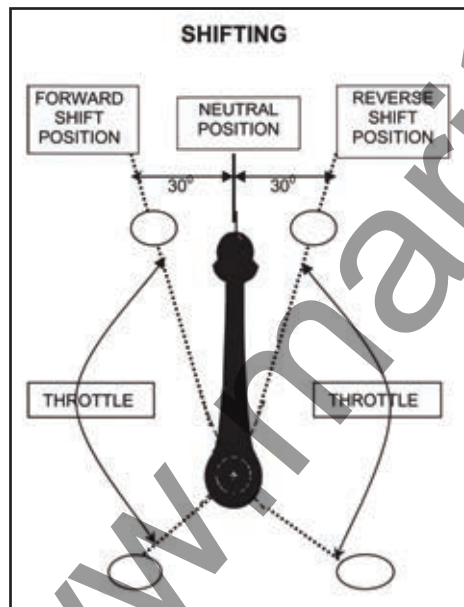

Figure 8.

### SHIFTING THE CONTROL.

To shift the control into forward or reverse, pull the umbrella up toward the knob and advance the handle forward (for forward travel) or rearward (for reverse travel) until the handle settles into a detent at approximately 30° of travel (see Figure 8). At this point, the control has engaged the gear and automatically entered the throttle mode where further advancement of the handle will increase the throttle. Once in the throttle mode, it is no longer necessary to pull on the umbrella. Increase or decrease throttle by simple moving the handle.

## Maintenance Notes

---

1. After a few hours of operation and at frequent intervals thereafter, check all fasteners and the complete control system for security and integrity.

### DANGER

**Loosening or loss of one or more fasteners may cause failure of the control system and could cause property damage, injury, or death.**

2. Keep all moving parts free from build-up of salt and other foreign material. This will affect their operation and create control problems.

3. Periodically inspect for corrosion. Any parts affected by corrosion must be replaced. Any replacement hardware must be as originally supplied (i.e. similar material and locking features).

4. Periodically inspect control cables for cracks and other damage. If any is found the cable must be replaced.

5. If cable is stiff in operation, it is unsafe to use and must be replaced immediately.

### DANGER

**DO NOT cover cracks with tape or other sealants. This will create a hazard in which the cable can fail suddenly without warning, resulting in property damage, injury, or death.**

### NOTICE

*Boat builder and boat dealer, please supply these Installation Instructions and Owner's Manual with the delivery of boat. Boat owner keep these instructions with your boat for future reference. Boat owner consult with your boat builder, boat dealer, or SeaStar Solutions if you have any questions regarding these instructions.*

