

Gunson®

CLIK-ADJUST MICROMETER TAPPET ADJUSTER

Valve clearance is made easier to adjust and absolutely precise, on all push rod engines or OHC engines with top adjustment with Clik-Adjust. This essential clearance adjustment ensures the valves (inlet and outlet) open and close correctly resulting in better engine performance.

Too little clearance goes unnoticed until valves fail to close and compression and power are lost. This can burn valves causing costly replacements or even causing an engine fire. Too great a clearance, although not so critical, results in noise and lost performance.

Valve Adjustment Sequence

Important: Make sure this sequence is established before attempting to adjust the valves. Consult the manufacturer's handbook or workshop manual for this information. Check whether the valves should be adjusted with the engine hot or cold.

Setting up and determining the number of clicks

Feeler gauges are used to determine the number of clicks required for a particular tappet clearance. Once the number of clicks is known, there is no further need for feeler gauges. The first time that Clik-Adjust is used on a particular job, fit the appropriate socket on to the 1/2" drive (C) and assemble the tool to the adjustment screw end of the rocker arm (refer to diagram below). Back off the tappet adjustment, then insert a feeler gauge of (for example) 0.010" (.25mm) in the gap between the

valve stem and rocker (H). The exact thickness of this initial feeler gauge is not important, it is simply used to provide a level surface between the valve stem and rocker. Turn the adjuster control (A) clockwise until a heavy click is felt and heard. All clearance has now been taken up. To set the tool, if (for example) the required clearance is 0.014" (14 thou), now back off adjuster control (A) and **count the clicks** until a 0.014" feeler gauge can just be inserted in the gap (H) (in addition to the 0.010" feeler gauge). This is then the **number of clicks required** to set the valve clearances to 0.014". Note: repeat this operation if the inlet and exhaust valves have different clearances (for example, inlet: 0.014", exhaust: 0.018").

Instructions:

Assemble the tool to the adjustment screw end of the rocker arm (refer to diagram below), using an appropriate socket for the adjustment nut.

- 1: Turn handle (B) anticlockwise to release the lock nut (G).
- 2: Press the built in screwdriver (E) down and locate the slot in the adjuster screw (F) of the tappet. Turn the adjuster control (A) clockwise until a heavy click is felt and heard.
- 3: Now turn the adjuster control (A) slowly anticlockwise, counting the clicks until the correct number of clicks is heard.
- 4: Keeping the adjuster control (A) completely still, tighten the lock nut (G) by rotating the handle (B) clockwise. The adjustment of this valve clearance is now complete. Follow the correct sequence for the remaining valves.

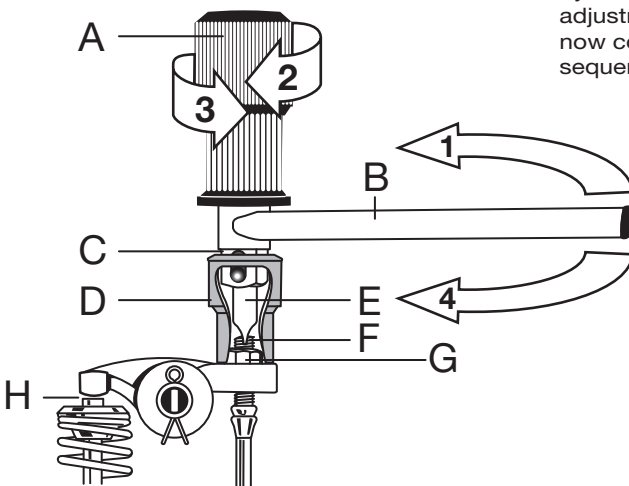

| | |
|---|------------------|
| A | Adjuster control |
| B | Handle |
| C | 1/2" drive |
| D | Socket |
| E | Screwdriver |
| F | Adjuster screw |
| G | Lock nut |
| H | valve clearance |

- NL** KLEPSTOTER MICROMETERREGELAAR
- F** AJUSTEUR DE POUSSOIR MICROMÉTRIQUE
- DE** MIKROMETER-VENTILEINSTELLSCHRAUBE
- IT** REGOLATORE MICROMETRICO PUNTERIE
- ES** AJUSTADOR DE LEVAS MICROMÉTRICO



When you have finished with this packaging please recycle it

www.gunson.co.uk



Distributed by The Tool Connection Ltd
Kineton Road, Southam, Warwickshire CV47 0DR
T +44 (0) 1926 815000 F +44 (0) 1926 815888
info@toolconnection.co.uk www.toolconnection.co.uk



5 018341 740948 >

Guarantee

If this product fails through faulty materials or workmanship, contact our service department direct on: +44 (0) 1926 818186. Normal wear & tear are excluded as are consumable items & abuse.